

TECHNICAL DATA

Filter type	NW 50	NW 62	NW 75	NW 50 TE
Diameter of pipe	2"	2 1/2"	3"	2"
Average flow rate (m ³ /hr) ΔP = 0,2 bar	20	25	30	1
Pressure (bar)	10	10	10	10
Max. operating pressure (bar)	16	16	16	16
Max. operating temperature	50° C	50° C	50° C	50° C
Weight (kg)	3,2	3,2	3,2	3,2
Standard filter sleeve	25 μ	25 μ	25 μ	—
Volume of the bowl	—	—	—	4,35 ltr
Filtration-surface	1 250 cm ²	1 250 cm ²	1 250 cm ²	—

INSTRUCTIONS

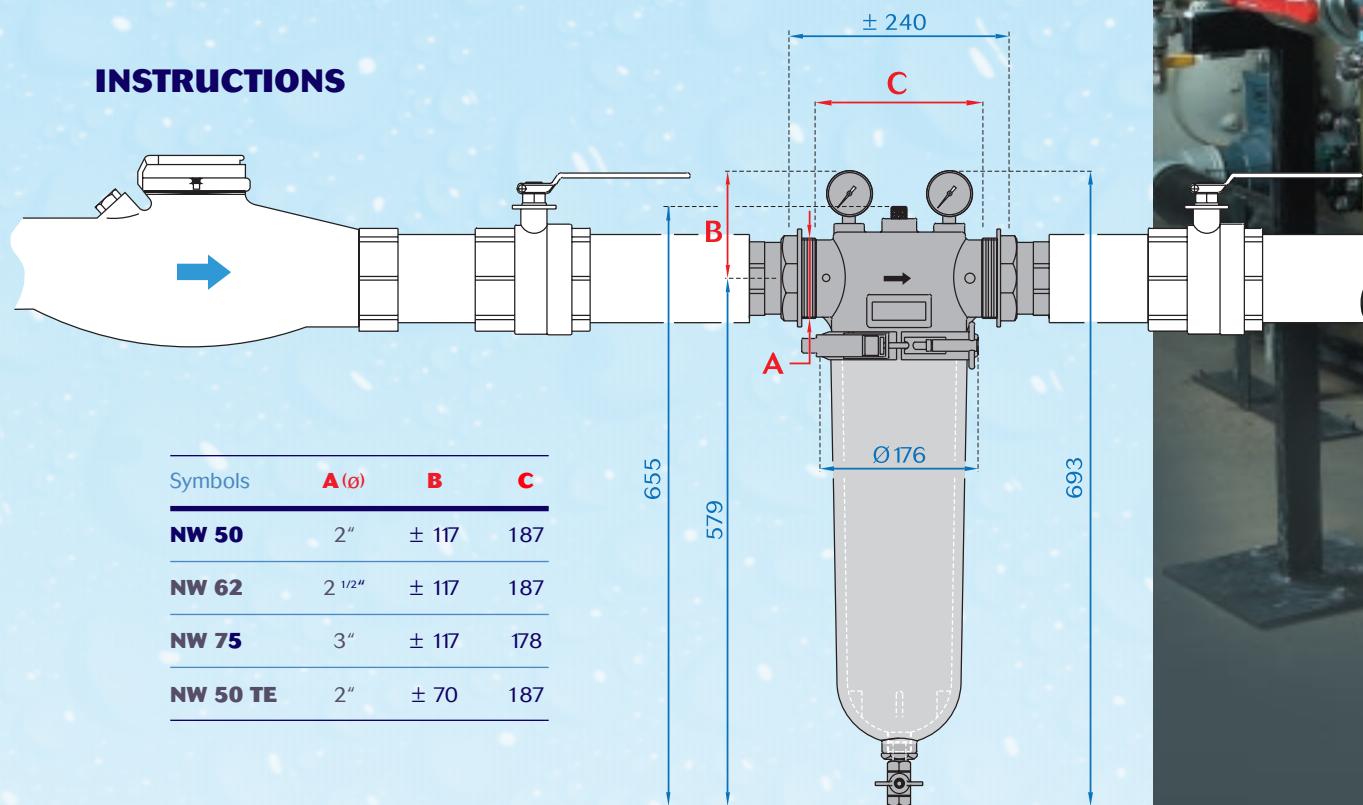

Symbols	A (ø)	B	C
NW 50	2"	± 117	187
NW 62	2 1/2"	± 117	187
NW 75	3"	± 117	178
NW 50 TE	2"	± 70	187

Your supplier :

cintropur®

WATERFILTRATION & TREATMENT

Industrial fluid filters

with centrifugal prefiltration



NW 50
ø2"

NW 62
ø2 1/2"

NW 75
ø3"

NW 50 TE
ø2"

Filtration

Standard filter delivered as shown (with a 25 µ filter sleeve).

Treatment

GENERAL DESCRIPTION

Made entirely from first quality synthetic material, CINTROPUR filters are perfectly suitable for food products and drinking water.

The CINTROPUR vane transforms the liquid flow into a centrifugal spin by throwing the larger particles down into the lower bowl, according to the chosen filter sleeve micron-size.

Basic principle

Protection of industrial as well as residential and agricultural installations by filtering the solid particles (earth, sand, rust, etc,...) suspended in the water.

APPLICATIONS

Industry : Protection of sanitary fittings and machine tools.

Agriculture : Filtration of watering (spraying) installations ;

Filtration of water for animals ;

Filtration of rainwater and well water.

Groups : (hotels, restaurants, schools, buildings, ...) protection of the sanitary installations and all electrical/domestic appliances.

Advantages :

- high and constant flow rate ;
- low pressure drop ;
- centrifugal prefiltration with a cyclonal effect ;
- robustness and reliability ;
- fast and easy flushing out ;
- permanent visual control of the filter sleeve (transparent bowl) ;
- exclusive system, ecological and not expensive (filter sleeve).

Water treatment

The water treatment (TE) models NW 50, 62 and 75 are equipped with a special device that allows the use of different water treatment products.

- *Polyphosphates, silicates and silicon-polyphosphates.*

Efficient up to 60°C, these products are used to reduce the harmful and scaling effects of the water hardness. The protection of new installations against rust is also a well known application.

- *Activated carbon*

The activated carbon Cintropur ROW 0.8 SCIN is sold separately and is highly suitable for the improvement of taste and the removal of odour, chlorine, ozone, micropollutants such as pesticides and other dissolved organic substances.



1 Pressure gauges 0-20 bar 1/4"

Gives the pressure of the installation. Filter sleeve to be changed at 1 bar ΔP, or at least three times a year.

2 Bayonet system

Fastening between the bowl and the filter head (4 key holes openings to fix the stainless steel lugs in the filter head) for a better and easier manipulation of the filter clamp.

3 Centrifugal vane

Fitted as standard with every filter sleeve model. The centrifugal force given to the liquid flow separates the "larger" particles by throwing them down into the lower bowl.

4 Drain cock 1/2"

Allows the draining under pressure of the larger particles collected by the centrifugal effect. The bowl is screwed into place by hand (no tools required).

ACCESSORIES

- A. Brass connections that can be dismantled**
2 part connections of the same diameter as the inlet/outlet and sealed by o-ring.
- B. Wall bracket**
In stainless steel and fastened onto the filter head with 2 pressure gauges. The same bracket for all the industrial filters.
- C. Black bowl**
Avoid the forming of algae while exposed to the direct sunlight.
- D. Device for chemicals TE**
Used for water treatment with activated carbon or polyphosphates. Can also be placed into the NW 62 and NW 75.

REFILL

- E. Filter sleeve (sets of 5 pieces)**
Non washable : 5µ / 10µ / 25µ / 50µ / 100µ
Washable : 150µ / 300µ
- F. Activated carbon**
Quality NORIT ROW 0,8 SCIN
Carton of 1,25 kg. For the bowls of NW 50TE, NW 62TE, NW 75TE : 1,65 kg. (detailed documentation available).



NW 50 TE
+ activated carbon

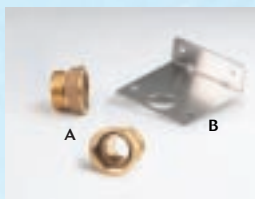

E